

Operating Instructions Manual

Submersible Mixed Flow Pump
(D-SMV, D-SMT Series)

2014. 10

DONG-A MACHINERY CO., LTD.



<Table of Contents>

Maintenance Guidelines

1. Introduction
2. Inspection
3. Structure
4. Transport and Installation
5. Storage
6. Operation
 - 6-1. Inspection before Operation
 - 6-2. Start-up
 - 6-3. Considerations during Operation
7. Trouble and Troubleshooting
8. Contact Information



Thank you for choosing the product of Dong-a Machinery Co., Ltd.

All of our members will make ceaseless efforts to provide quality products for your safety and convenience. This Maintenance Guidelines lists the information needed for the efficient maintenance of our water pumps.

Maintenance Guidelines

Please read the user's manual thoroughly before using the water pump motor.

This is to prevent any accidents or risks that may occur while using this product to ensure its safe and proper use.



[Danger] Will cause serious injuries or death instantly if not observed.



[Warning] May cause serious injuries or death if not observed.



[Caution] May cause minor injuries or failure of product if not observed.



Danger

[Danger]

When measuring insulation resistance, do not contact the electric motor socket and frame directly and always discharge electricity after measuring. May cause an electric shock and lead to critical injuries.

※ Do not install if the product is delivered damaged and contact the seller.

※ Always disconnect power when measuring insulation resistance.

May cause an electric shock and lead to critical injuries.

※ Check that the power is disconnected before connecting the wires.

High-voltage current flows through the wires and may cause an electric shock that leads to death or severe injuries.

※ When connecting the power cable, follow the wiring drawing or the user's manual.

※ Always install earthing when wiring.

※ May cause mechanical failure or critical accidents when power is supplied.

※ Do not operate while the leak sensor is in operation. Also, disconnect power immediately if the leak sensor operates during operation.

※ Disconnect power before measuring the insulation resistance of electric motor or starting the repair work. May cause an electric shock.



Do not randomly refurbish or modify the parts when repairing.
May damage the performance of motor and cause injuries or losses.



Warning

[Warning]

※ The power cable of the electric motor must be fixed before transport and use caution so the cable is not impacted or damaged while handling.

The cable's sealing part at the connection to the electric motor unit may be damaged under impact to cause a leak.

※ The electric motor unit should be protected from external impact.

The sealing parts may lose sealing capacity to cause a leak.

※ The power cable and the control cable at the top of the motor should be fixed in place and the end of the cable should be sealed (plastic or cable cap) for protection from humidity.

※ Measure insulation resistance using 1000V Megger Tester once every 3 months to ensure that it stays above the threshold.

※ When storing the motor without the cables connected after installation, the ends of the cables must be sealed and must not be submerged underwater.

Water may transfer into the motor unit through the cables.

※ Use the Megger Tester to check the wiring condition before start-up.

※ Check the condition of leak sensor.

※ Repeated testing may overheat the motor and damage its wiring. For repeated testing, wait for a sufficient length of time in between each testing.

※ When lifting the motor for maintenance/repair, use caution so its main unit and cables are not damaged or impacted.

※ In case of repair, disassembly, or assembly, read the user's manual and use appropriate protective gear before the work.

※ The mechanically processed surface that is connected to the O-ring must be protected from damage as it may cause a leak.

※ When assembling, the gaskets inside the O-ring or the cable gland must not be reused.

The gaskets and the O-ring significantly lose the sealing capacity when disassembled, reusing them for operation underwater causes a leak.

※ When disassembling the rotor, the shaft should be handled carefully to prevent any damage (especially the mechanical room unit).



 주의 Caution**[Caution]**

Check if the voltage and frequency on the motor's specification label match the actual voltage and frequency. The condition of operation is not required to match the specifications, but the voltage should be within $\pm 10\%$ of fluctuation and the frequency within $\pm 5\%$.

If the voltage and frequency change simultaneously, the sum of absolute percentage of fluctuation should be within 10%.

※ Disassembly should take place in a clean place.

※ The parts should be marked or stored in separate cases in case of disassembly so they can be re-assembled in the right places.

※ Check the order and method of disassembly and assembly to determine the order of operation and appoint an experienced person with sufficient knowledge and experience.

※ As the inside of top cover is connected to the power cable and the cable from the motor stator, lift the top cover slowly to check the inside. Lifting it up too quickly can damage the power cable and the cable connection, damage the cable connection inside the motor, and/or forcefully separate the control cable from the socket.

※ Use the disassembly jig when disassembling the bearing.

Do not reuse the bearing once it is disassembled.

※ Heat the bearing for shrinkage fitting for assembly.

In case of shrinkage fitting, the bearing should be heated evenly throughout.

Never use a torch lamp to heat the bearing as it may cause damage.

안전상의 주의

다음에 나오는 표시는 경고, 주의, 주기 표시로 이 제품을 취급할 때에 주의해야 할 문구 앞에 붙어, 제품을 취급하시는 분에게 사고 발생 가능성을 단계별로 예견해주고 있습니다.



 **위험**

취급을 잘못된 경우에 사망 또는 중상을 입는 절박한 위험상황.

 **경고**

취급을 잘못된 경우에 사망 또는 중상을 입는 위험한 상태가 발생할 가능성을 경고.

 **주의**

취급을 잘못된 경우에 경상을 입거나 물적 손해 등이 발생할 가능성을 주의.

주기

제품을 올바르게 취급하기 위해 별도로 적어두거나 알고 있어야 할 때에 주지시킴.

 **경고**

- 온도가 높은 부품을 다루거나 취급할 때에는 직접 살에 닿지 않도록 방열장갑 등을 착용해 주시기 바랍니다.
- 펌프를 옮기거나 매달아 올릴 때에는 매달려고 하는 펌프의 중량을 고려하여 그 중량에



맞는 크레인 또는 호이스트 및 와이어로프를 사용해야 합니다. 펌프에 와이어를 거는 위치와 펌프와 와이어와의 장력을 조사하여 하중이 어느 한쪽으로 치우치지 않게 하여야 합니다. 이것을 지키지 않으면 중대한 인명사고가 발생할 수 있습니다.

- 펌프를 사용하지 않고 정지상태에 있을 시에는 동료나 주위에 있는 사람이 원동기를 가동 하지 않도록 전원스위치를 미리 끊어 주시기 바랍니다.
- 펌프를 분해할 시에 항상 주위에 있는 사람에게 작업행동을 주지시켜, 실수로 원동기가 작동되지 않도록 해야 합니다. 이 조치를 취하지 않은 경우 중대한 인명사고가 발생할 수 있습니다.
- 펌프의 분해와 수리는 반드시 기술자가 해야 합니다. 기술자 이외의 사람이 분해, 수리를 하는 중에 인명사고를 발생시킬 수 있습니다.
- 점검과 수리 때. 정전 시에는 전원 스위치를 반드시 차단하여 주십시오. 펌프가 갑자기 시동하여 부상의 원인이 됩니다.



제 1 장 구 조



1. Introduction

This user's manual provides the information needed for the proper use of water pump motor.

Read the manual thoroughly before its transport, installation, operation, and repair to prevent any casualties or losses caused by explosion, fire, or electric shock due to proper use.

This user's manual is needed for everyday inspection and troubleshooting, so store it in a conspicuous place after reading it.

2. Inspection

Please check the following when you first receive the product:

1) Check that the required specifications match the specifications on the label.

The label indicates the flow, lift, output, number of poles, voltage, frequency, and model.

2) Roughly measure the external dimensions to ensure that it can be installed at the given space.

3) Check that the power cable is long enough to reach the JUNCTION BOX or PANEL.

4) Check whether the product has been delivered damaged.

If the product has been damaged, inspect it immediately and contact the seller.

5) Check if any bolts or nuts are not fastened.

If the bolts are not fastened, they will cause a leak.

6) Use an Megger Tester to measure the resistance and secure the condition of insulation.

There is no requirement for insulation resistance as it varies significantly according to the system's temperature, vapor absorption, and cleanliness. Its reference formula is as follows:

$$\frac{\text{Ratedvoltage}(V)}{\text{ratedoutput}(kW) + 1000} (M\Omega), \text{ or } R = \text{Ratedvoltage}(kW) + 1 (M\Omega)$$

7) Use a multi-tester to measure the resistance of motor protectors (sensors) to ensure that they are free of defects.

8) Also check the power switch and the starter system.

Check that the protectors are working properly, the insulation resistance is high enough, the fuse capacity is appropriate, and the cable connection or wiring is done correctly before supplying power.

If any problem is found during inspection, contact the seller.





Danger

When measuring insulation resistance, do not contact the electric motor socket and frame directly and always discharge electricity after measuring. May cause an electric shock and lead to critical injuries.

※ Do not install if the product is delivered damaged and contact the seller.

3. Structure

The product's structure is as shown below.

For detail, refer to the specifications.

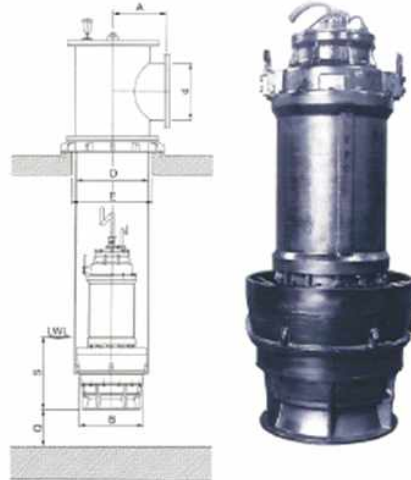

4. Transport and Installation

You need a crane and wire rope to transport the product.

- 1) Please use caution for the safety of workers when transporting and to protect the product from damage.
- 2) When lifting with a crane, connect the wire rope to the eye bolt or hook on the top of electric motor and lift slowly.
- 3) Check if the cables have been submerged underwater or damaged before installation.
- 4) To store the product after use, remove moisture and apply anti-rust treatment to prevent rusting.
- 5) The fluids in the pump should use purified water, such as tap water.
- 6) When connecting the pump to the piping, the pump should be horizontal/vertical.
- 7) When installing the pump to the piping, check the direction of inflow and outflow of



water.

- 8) The cables must be free of damage and must not be submerged underwater.
- 9) Check the movement of drain connected to the stuffing box and ball tabs installed on the water seal line, and the condition of switch.
- 10) When disassembling the polycarbonate windows on both sides of stuffing box, check if the gaskets have defects and fasten the bolts to keep the water out.

5. Storage

When the equipment is not in use, it should be stored in a clean, dry place.

If it is exposed to humidity or dust, cover it with a plastic cover to prevent rust.

When moving from a cool place to a warm place, the equipment should be covered.

Condensation may occur if handled without caution and power should be supplied to dry the equipment completely if there is the risk of condensation or humidity.

Check the following if the electric motor is stored and not operated for a long time.

5-1. To store the electric motor for a long time in packaging:

- 1) Store in a clean, dry place with no vibration or temperature fluctuation.
- 2) The rotor should be rotated every month to refill the lubricant in the bearing. If stored for more than 6 months, the same type of oil or grease in the bearing should be refilled every 6 months. No need to refill ZZ bearing.
- 3) Measure the insulation resistance and check if the bearing has any defect.



Warning

[Warning]

The power cable and the control cable at the top of the motor should be fixed in place and the end of the cable should be sealed (plastic or cable cap) for protection from humidity.

5-2. If not used for a long time after installing the electric motor

(more than 6 months in normal condition or 3 months in high temperature/humidity):

- 1) Refer to <Installation> for the place of installation.
- 2) When there is high humidity or the risk of water penetration or impurities, the electric motor should be sealed with plastic and seal a dehumidifying agent inside. The dehumidifying agent should be replaced from time to time.
- 3) Operate in idle once every 3 months to refill the lubricant in the bearing and inject the same type of oil or grease every 6 months when stored for more than 6 months.



- 4) Use the 1000V Megger Tester (Mega) once every 3 months to measure the insulation resistance and check that it is below the threshold.
- 5) Measure the insulation resistance, inspect the bearing, and check the connection to power before use.

 경고 Warning

[Warning]

Measure insulation resistance using 1000V Megger Tester once every 3 months to ensure that it stays above the threshold.

※ When storing the motor without the cables connected after installation, the ends of the cables must be sealed and must not be submerged underwater.

Water may transfer into the motor unit through the cables.

 주의 Warning

[Warning]

※ Do not operate while the leak sensor is in operation. Also, disconnect power immediately if the leak sensor operates during operation.

6. Operation

Please check the following for operation:

6-1. Inspection before Operation

 위험 Danger

[Danger]

※ Check that the power is disconnected before connecting the wires.

High-voltage current flows through the wires and may cause an electric shock that leads to death or severe injuries.

※ When connecting the power cable, follow the wiring drawing or the user's manual.

※ Always install earthing when wiring.



 경고 Warning**[Warning]**

Use the Megger Tester to check the wiring condition before start-up.

 주의 Caution**[Caution]**

※ Check if the voltage and frequency on the motor's specification label match the actual voltage and frequency. The condition of operation is not required to match the specifications, but the voltage should be within $\pm 10\%$ of fluctuation and the frequency within $\pm 5\%$.

If the voltage and frequency change simultaneously, the sum of absolute percentage of fluctuation should be within 10%.

1) Check that all wires of the electric motor are connected for operation.

Refer to the wiring drawing to check the power connection and the protective gears, the condition of each connection, and the insulated parts that must not be electrically connected.

Measure the resistance of leak sensor that can detect water intrusion into the electric motor to ensure that there is no leak.

2) The unit must use earthing as there is earthing line in the power cable.

Generally, there are 4 lines for high voltage (3 for power cable and 1 for earthing) and 7 lines for low voltage (6 for power cable and 1 for earthing).

6-2. Start-up

Please check the following for start-up:

 위험 Danger

※ Turn the power switch off when there is power outage during operation.

It may cause mechanical damage or critical accidents when the power comes back.

 경고 Warning**[Warning]**

※ Repeated testing may overheat the motor and damage its wiring. For repeated testing, wait for a sufficient length of time in between each testing.

1) Measure power voltage and check if the 3 phases achieve equilibrium and match the rated voltage of electric motor.



2) Supply power for a moment to check the direction of rotation in normal operation. Check that the motor is rotating clockwise when viewed from the top when it is rotating by inertia. If it rotating counterclockwise, change the wiring and check again.

① Check if there is abnormal noise or abnormal vibration.

② Check if there is smoke from the inside of electric motor.

3) Check and adjust inflow pressure and outflow pressure in normal operation. Carefully observe the bearing temperature and vibration during operation.

4) Check that the direction of rotation matches the direction in the drawings or on the label when operating under rated load.

- Check the following as the direction of rotation cannot be checked when submerged underwater:

① Check the ampere meter to check that the current is close to the rated current.

If the rated current is significantly lower than the normal value, the direction of rotation is opposite (provided that other conditions are normal).

② Check the flowmeter to check that the flow is normal. If the flow is significantly lower than the normal value, the direction of rotation may be opposite (provided that other conditions are normal).

6) If there is a problem, refer to Troubleshooting to correct the abnormality.

7) The bearing and the mechanical seal should be replaced every 3 years in normal operation.

8) The water inside the pump should be discharged if not used in winter to prevent freezing.

9) Avoid overloading.



7. Trouble and Troubleshooting

The causes of trouble can be summarized as below. Please check the related causes to restore the normal operating condition in case of trouble.

Item	Cause	Troubleshooting
* Insufficient lift	Abrasion of bearing	Impurity infiltration
		Overly worn bushing
	Cavitation	Low water level Clogged inlet
	Air infiltration	Low water level
* Insufficient flow	Abrasion of bearing	Impurity infiltration
		Worn bushing – Shaft force
	Opposite rotation and lack of rotation	
	Damaged guide casing	
	Air filtration	Low water level
* Overloaded motor	Abrasion of bearing	Impurity infiltration
		Shaft force
	Insufficient flow	Closed outflow valve
	Overly worn bushing	Impossible to inject lubricant
Shaft force		
	Poor centering of coupling	
* Vibration	Abrasion of bearing	Impurity infiltration
		Worn bushing – Shaft force
	Cavitation	Low water level
		Clogged inlet
	Air infiltration	
	Unbalanced rotor	
Poor centering		
	Contact with wet moving part	
* High temperature of bearing	Abrasion of bearing	Impurity infiltration
		Worn bushing
	Poor lubrication	Lack of lubricant
Inappropriate lubricant Impurities in lubricant		
	Poor rotor	
* Leak from stuffing box	Poor O-ring/gasket	
	Damaged M/Seal	



8. Contact Information

In case of failure or general inquiries, please check the following and contact us:

1). Information on label

(especially diameter, model, flow, lift, power, number of rotation, and manufacture no.)

2). In case of failure, please elaborate the place of failure, condition, and operability.

3). Please refer to the following information to contact us:

동아기공

주소 : 인천광역시 남구 봉수대로 55-49

전화 : 032) 582-0048

FAX : 032) 581-5374

[http:// www.donga21.net](http://www.donga21.net)

DONG-A MACHINERY CO., LTD.

55-49, Bongsu-dearo, Nam-gu, Incheon, Korea

Tel : + 82-32-582-0048

Fax : + 82-32-581-5374

[http:// www.donga21.net](http://www.donga21.net)

